

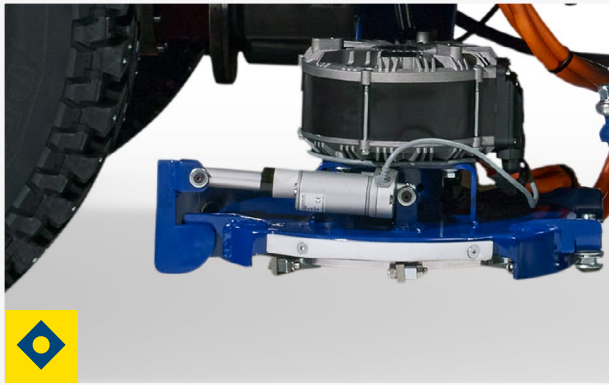





## **BUILT FOR THE ICE. DESIGNED FOR THE ICE MAKER.**

Optimizing familiar technologies and automating processes, the ZX5 allows for consistency between operators and savings of time and resources.





-  Optional Euro Edger saves time, performing edging during a regular resurfacing
-  Optional joystick for ease of operation and automated blade/water control for consistency between operators
-  Capacities match or exceed those of the Zamboni 500 Series models
-  Quick blade change system with left and right side access for a faster, safer process



This brochure has been prepared only as a general guide for the customer. Every effort has been made to assure that the information presented is correct. Some features described or shown may be optional at extra cost. Prices, colors, materials, specifications and models are subject to change. For current product information, please contact the Zamboni Company.



## STANDARD EV PLUG CHARGING

Facilities can procure the charger of their choice or use existing Level 1 or Level 2 EV charge stations to replenish the lithium-ion batteries between resurfacings.



## MISSION CONTROL

Electronic controls at your fingertips. Digital dash display features state of charge, water consumption/temperature, ground speed, blade adjustment, enhanced diagnostics, and optional systems such as FastICE® and Level-Ice®. All machine functions are coordinated, streamlining its operation, and maximizing efficiencies.



## ENERGY EFFICIENCY

Resurfacing parameters can be optimized to conserve energy and water. State-of-the-art hydraulics and a reimagined power train deliver a more efficient design that reduces the amount of energy used during a resurfacing.



## LOW MAINTENANCE

Lithium-ion batteries are sealed and maintenance-free. Corrosion-free removable body panels and a slide-out battery tray allow ease of access. Scheduled maintenance alerts are programmed and displayed via the on-dash touchscreen.



## GLOBAL SERVICE AND SUPPORT

Zamboni Customer Service and a network of Zamboni Authorized Distributors provide exceptional and accessible service and support worldwide.

**ZAMBONI**  
zamboni.com

ZAMBONI and the configuration of the Zamboni® ice resurfacing machine are registered trademarks of Frank J. Zamboni & Co., Inc.  
© Zamboni 2025

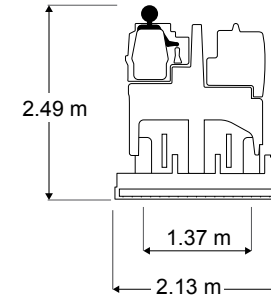
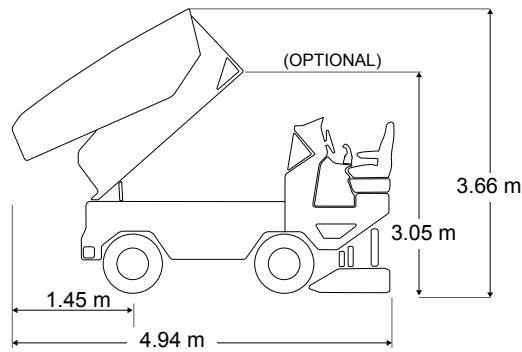
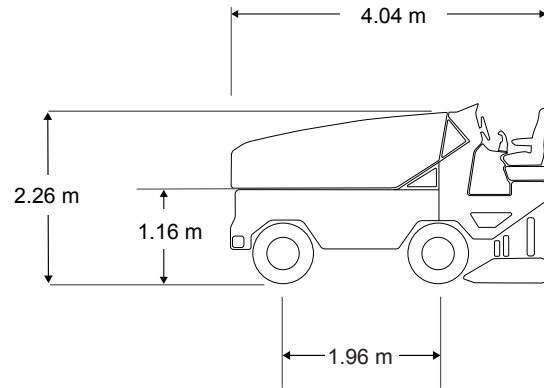

### CAPACITIES

#### Snow Tank

Actual Volume	2.83 m <sup>3</sup>	100 cu. ft
Compacted	3.54 m <sup>3</sup>	125 cu. ft

#### Water

Ice Making	760 L	200 gal.
Wash Water	268 L	70 gal.
Total	1028 L	270 gal.

<b>Hydraulic Oil</b>	95 L	25 gal.
----------------------	------	---------

### POWERTRAIN

#### Motors

Electric Hydraulic Pump Motor	10 kW	13 HP
Electric Traction Motor (2)	20 kW (per motor)	27 HP

<b>Battery</b>	Lithium-ion	
----------------	-------------	--

#### Axles

Front	770 kg	1693 lb
Rear	3370 kg	7431 lb

### DIMENSIONS

#### Overall

	L	W	H	L	W	H
Snow Tank Down	4.04 m	2.13 m	2.26 m	159 in.	84 in.	89 in.
Snow Tank Up	4.94 m	2.13 m	3.66 m	194 in.	84 in.	147 in.

#### Shaving Blade

	L	W	H	L	W	H
195.6 cm   77 in. Blade	195.6 cm	12.7 cm	1.27 cm	77 in.	5 in.	0.5 in.

#### Clearance

Minimum Operator Height Clearance	2.49 m	96 in.
Snow Pit Clearance	1.16 m	46 in.

#### Conveyor System

Horizontal Auger Diameter	25.4 cm	10 in.
Vertical Auger Diameter	25.4 cm	10 in.

#### Manueverability

Wheelbase	1.96 m	77 in.
Wheel Track	1.37 m	54 in.
Turning Radius at Conditioner	4.57 m	15 ft.

#### Weight

Empty	3210 kg	7080 lb
With Water	4140 kg	9120 lb

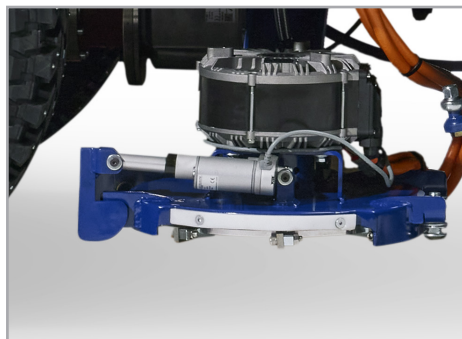

### Euro Edger +

The onboard edger saves time, performing the edging process during a routine resurfacing.



### Joystick Controller +

The joystick controller provides additional familiarity and ease of operation for routine resurfacing processes.



### 12" Digital Touch Display ✓

The larger digital display increases visibility and allows touch navigation to access information on the go.



## ✓ STANDARD

2 Year Warranty  
4WD  
Advanced Water System  
Auto Ice: Automated Resurfacing  
Battery: Lithium-ion  
Battery: Slide-out Battery Tray  
Blade Adjustment: Electric  
Board Brush: Conical  
Body Panels: Removable  
Charger: Onboard EV Compatible Charger  
Charging Port: Left Side  
Chassis: Welded Steel  
Corrosion-resistant Poly IMW Tank  
Display: 12" Digital Touch Screen  
Emergency Stop  
Guide Wheel  
Headlights: LED  
Hydraulic Oil Level Sight Gauge  
Hydraulic Oil Temperature Sensor  
Ice Making Water Level Gauge

Ice Making Water Pipe: Stainless Steel  
Motors: Brushless AC Motors  
Motors: Dual Electric Traction Motors  
On-Dash Diagnostics  
Parking Brake  
Power Steering  
Safety: Dual Snow Tank Safety Stands  
Service Manual: Online  
Snow Breaker: Automatic  
Snow Tank Light  
Stainless Steel Hardware  
Tires: Tungsten Carbide Studded  
Towel: Durable Polyester Felt  
Wheels: Aluminum Alloy  
Wide Spectrum of Premium Paint Colors

## + OPTIONS

Auger Washout System  
Board Brush: Cylindrical Power Brush™  
Charging Port: Right Side  
Chassis: Galvanized Steel  
Conditioner: Galvanized Steel  
Conditioner: Quick Blade Change System  
Euro Edger: On Board Edger  
FastICE® Advanced Ice Making System  
Ice Making Water Temperature Sensor  
IceCaps® Wheel Advertising System  
Joystick Controller  
Level-Ice® Laser Leveling System  
Light: Body Flashing Light  
Lighting: Body Accent Lights  
Multiview Camera System  
Proximity Sensor System  
Safety: Backup Alarm  
Seat Belt  
Seat: Heated Comfort Seat  
Snow Tank Dump Height Restriction

Snow Tank Window Lift: Electric  
Snow Transfer Light  
Tire Wash System  
Towel Lift: Electric  
Turn Signal  
Wash Water: 400 Micron Deep Filter Bag  
Wash Water System With Poly Tank  
Wash Water Temperature Sensor  
Water Transfer Valve: Electronic  
Zamboni Connect™ System