

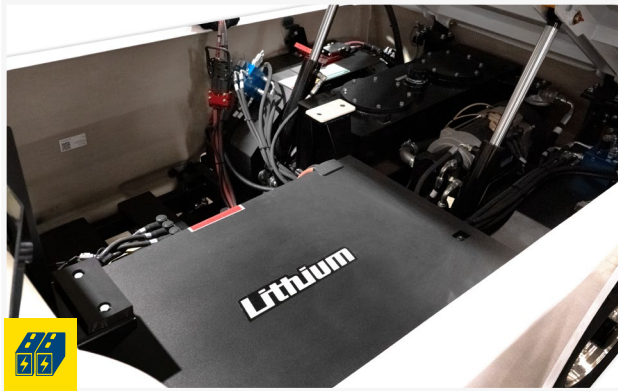

ALL IT LEAVES BEHIND IS PERFECT

Lithium-ion or lead acid battery power available with a variety of capacities to support busy arena schedules

MODEL
650
ELECTRIC



Also available with lead acid batteries which do require overnight charging and regular battery maintenance



Platform redesigned with a focus on safety, comfort and ease of operation



Exceptional results from our unrivaled down pressure system

MODEL 650 ELECTRIC



This brochure has been prepared only as a general guide for the customer. Every effort has been made to assure that the information presented is correct. Some features described or shown may be optional at extra cost. Prices, colors, materials, specifications and models are subject to change. For current product information, please contact the Zamboni Company.



BATTERY AND CHARGER

Lithium-ion batteries charge quickly between resurfacings while maintaining power. Sealed minimal maintenance batteries are truly emission-free. Charging is controlled by battery management system to optimize charging and balancing.



ELECTRONIC CONTROLS

Dependable Sevcon® Gen4 AC controls. On-dash diagnostics provide real-time management of machine functions and status updates.



DRIVETRAIN

Four-wheel drive. Rugged Dana Spicer® axles combine with a 24 hp AC traction motor, providing the most reliable drivetrain in the industry.



HYDRAULICS

The redesigned hydraulic system provides optimum power and reduced energy consumption for smooth and consistent operation. 11 hp AC pump motor.



CONSTRUCTION

A clean sheet design with strategic component placement for efficiency. Fiberglass body panels, premium paint and robust hand-welded steel tubing chassis.



GLOBAL SERVICE AND SUPPORT

Zamboni Customer Service and a network of Zamboni Authorized Distributors provide exceptional and accessible service and support worldwide.

ZAMBONI

zamboni.com

ZAMBONI and the configuration of the Zamboni® ice resurfacing machine are registered trademarks of Frank J. Zamboni & Co., Inc.
© Zamboni 2025

MODEL 650 ELECTRIC

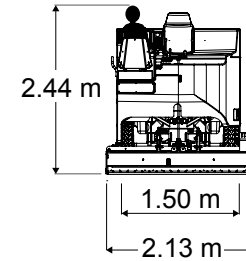
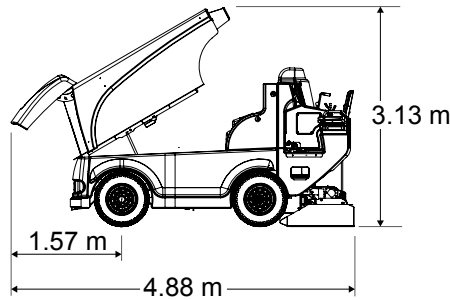
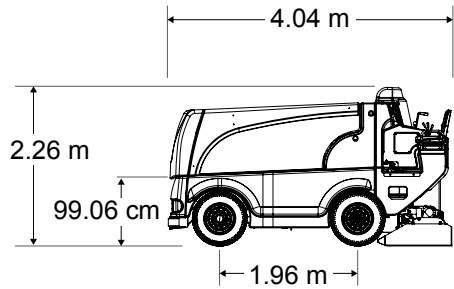

CAPACITIES

Snow Tank

Actual Volume	3.0 m ³	106 cu. ft.
Compacted	3.74 m ³	132 cu. ft.

Water

Ice Making	757 L	200 gal.
Wash Water	227 L	60 gal.
Total	984 L	260 gal.

Hydraulic Oil

91 L	24 gal.
------	---------

POWERTRAIN

Four-Wheel Drive

Motors

AC Hydraulic Pump Motor	8.2 kW	11 HP
AC Traction Motor	17.9 kW	24 HP

Battery

✔ Lead Acid or + Lithium-ion *Accommodates a Variety of Battery Capacities

Axles

Front	2717 kg	5990 lb
Rear	4159 kg	9170 lb

✔ Standard + Option

DIMENSIONS

Overall

	L	W	H	L	W	H
Snow Tank Down	4.04 m	2.13 m	2.26 m	159 in.	84 in.	89 in.
Snow Tank Up	4.88 m	2.13 m	3.13 m	192 in.	84 in.	123 in.

Shaving Blade

	L	W	H	L	W	H
195.6 cm 77 in. Blade	195.6 cm	12.7 cm	1.27 cm	77 in.	5 in.	0.5 in.

Clearance

Minimum Operator Height Clearance	243.8 cm	96 in.
Snow Pit Clearance	99.06 cm	39 in.

Conveyor System

Horizontal Auger Diameter	25.4 cm	10 in.
Vertical Auger Diameter	25.4 cm	10 in.

Manueverability

Wheelbase	1.96 m	77 in.
Wheel Track	1.50 m	59 in.
Turning Radius at Conditioner	4.83 m	15 ft. 10 in.

Weight

Empty with Lead Acid battery	4853 kg	10700 lb
with Water with Lead Acid battery	5670 kg	12500 lb
Empty with Lithium-ion battery	3402kg	7500 lb
with Water with Lithium-ion battery	4220kg	9300 lb

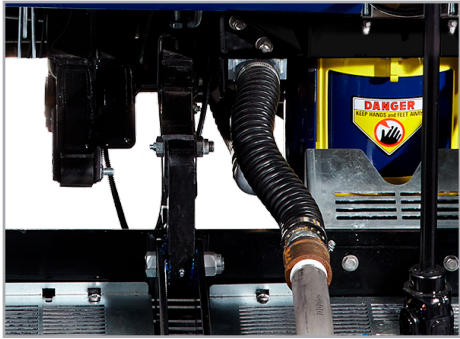

Automatic Snow Breaker

Eliminates the need for manual control of the snow breaker by the machine operator.



Zamboni Power Brush™

Wider brush path reaches higher on the dasher board kick plate for superior cleaning power.



Ergonomic Seat

Designed with the operator in mind, our premium seat has optimal adjustability.

*optional equipment

MODEL 650 ELECTRIC

✓ STANDARD FEATURES

- 2 Year Warranty
- 400 Micron Wash Water Deep Filter Bag
- Aluminum Alloy Wheels
- Automatic Snow Breaker
- Battery: Lead Acid
- Battery Charger: Microprocessor Controlled
- Brushless AC Motors
- Chassis: Strong All Welded Steel Tubing
- Conditioner Safety Guards
- Dependable Sevcon® Gen4 Controls
- Digital Training and Reference Materials
- Dual Water Fill Pipes
- Electric Water Level Gauge
- Four-Wheel Drive
- Guide Wheel
- High Quality 9 Micron Filter
- High Speed Vertical Auger
- Hydraulic Oil Level Sight Gauge
- LED Headlights and Tail lights
- On-Dash Diagnostics
- Operator Area Storage Bins
- Parking Brake
- Power Steering
- Premium Polyester Felt Spreader Towel
- Replaceable Poly Conditioner Side Plate
- Rugged Dana Spicer® Axles
- Rust-Free Poly Ice Making Water Tank
- Rust-Free Poly Wash Water Tank
- Single Point Battery Watering System
- Snow Tank Maintenance Support
- Spare Tire and Wheel
- Stainless Steel Water Distribution Pipe
- Steering Wheel Spinner Knob
- Touch-Up Paint Kit
- Tungsten Carbide Studded Tires
- Wide Spectrum of Premium Automotive Paint Colors
- Zamboni Power Brush™ Board Brush System

+ OPTIONS

- Advanced Water System (AWS™)
- Back Up Alarm
- Battery: Lithium-ion
- [Blade Change System](#)
- Board Spray
- Conditioner: 96" Blade
- Conditioner: Galvanized
- [FastICE® Ice Making System](#)
- Heated Ergonomic Comfort Design Seat
 - Armrest
 - Seatbelt
- IceCaps® Wheel Advertising System
- [Level-Ice™](#)
- Rotating Beacon Light
- Snow Tank Light
- Tire Wash System
- Wash Water to Ice Making Water Transfer
- [Zamboni Connect™ System](#)