

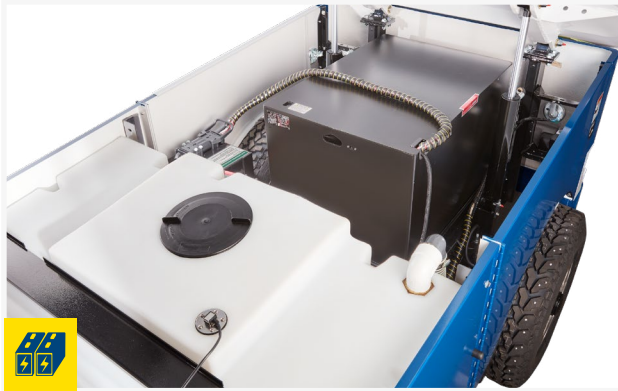

## RESURFACE, RECHARGE, REPEAT...

Lithium-ion battery power provides the ultimate upgrade to the world's most popular electric ice resurfacer

**MODEL**  
**552** AC  
**ELECTRIC**



Also available with lead acid batteries which do require overnight charging and regular battery maintenance



Vertical auger enclosure reduces operator area sound levels



Exceptional results from our unrivaled down pressure system

# MODEL 552<sup>AC</sup> ELECTRIC

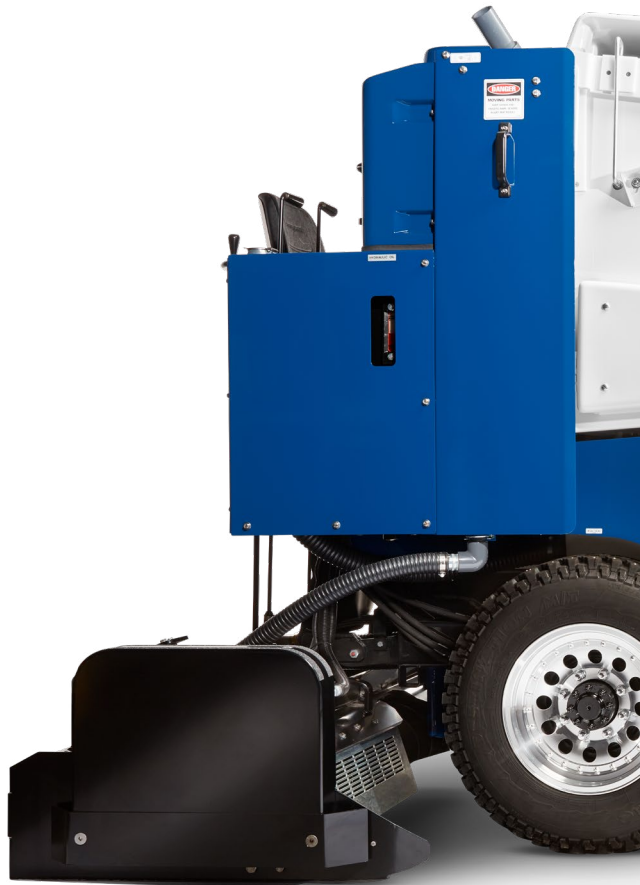

This brochure has been prepared only as a general guide for the customer. Every effort has been made to assure that the information presented is correct. Some features described or shown may be optional at extra cost. Prices, colors, materials, specifications and models are subject to change. For current product information, please contact the Zamboni Company.



## BATTERY AND CHARGER

Lithium-ion batteries provide the ability to quickly charge between resurfacings while maintaining power. Sealed minimal maintenance batteries are truly emission-free. Charging is controlled by battery management system to optimize charging and balancing.



## ELECTRONIC CONTROLS

On-dash multi-function display features a battery discharge indicator, hour meter and diagnostic information. Dependable Sevcon® Gen4 controls are proven in tough industrial applications.



## DRIVETRAIN

Four-wheel drive with rugged Dana Spicer® axles and a 24 hp traction motor, providing the most reliable drivetrain in the industry.



## HYDRAULICS

11 hp AC pump motor provides optimum power and reduced energy consumption for smooth and consistent operation.



## CONSTRUCTION

Robust hand-welded steel tubing chassis and rust-free poly water tanks for durability in the harsh environment it will call home.



## GLOBAL SERVICE AND SUPPORT

Zamboni Customer Service and a network of Zamboni Authorized Distributors provide exceptional and accessible service and support worldwide.

# ZAMBONI

[zamboni.com](http://zamboni.com)

ZAMBONI and the configuration of the Zamboni® ice resurfacing machine are registered trademarks of Frank J. Zamboni & Co., Inc.  
© Zamboni 2025

# MODEL 552<sup>AC</sup> ELECTRIC

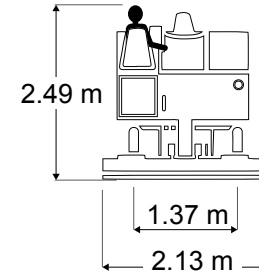
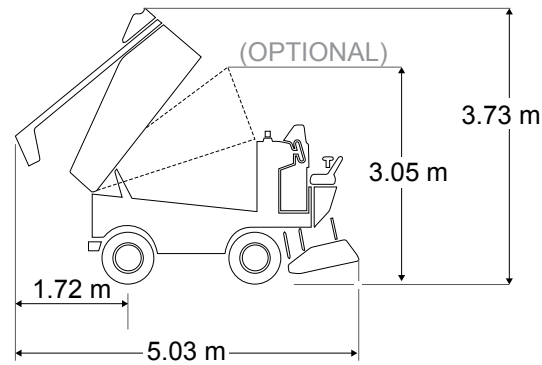
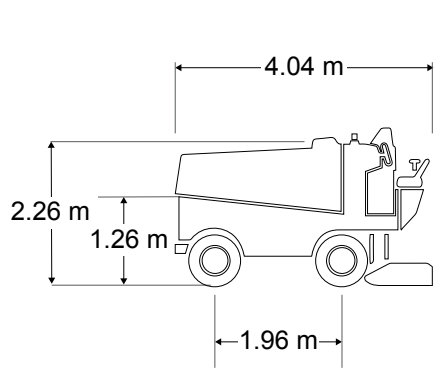

## CAPACITIES

### Snow Tank

|               |                     |             |
|---------------|---------------------|-------------|
| Actual Volume | 2.83 m <sup>3</sup> | 100 cu. ft. |
| Compacted     | 3.54 m <sup>3</sup> | 125 cu. ft. |

### Water

|            |        |          |
|------------|--------|----------|
| Ice Making | 738 L  | 195 gal. |
| Wash Water | 310 L  | 82 gal.  |
| Total      | 1048 L | 277 gal. |

|                      |        |         |
|----------------------|--------|---------|
| <b>Hydraulic Oil</b> | 60.6 L | 16 gal. |
|----------------------|--------|---------|

## POWERTRAIN

Four-Wheel Drive

### Motors

|                               |         |       |
|-------------------------------|---------|-------|
| Electric Hydraulic Pump Motor | 8.2 kW  | 11 HP |
| Electric Traction Motor       | 17.9 kW | 24 HP |

### Battery

✔ Lead Acid or + Lithium-ion \*Accommodates a Variety of Battery Capacities

### Axles

|       |         |         |
|-------|---------|---------|
| Front | 2903 kg | 6400 lb |
| Rear  | 2903 kg | 6400 lb |

✔ Standard + Option

## DIMENSIONS

### Overall

|                | L      | W      | H      | L       | W      | H       |
|----------------|--------|--------|--------|---------|--------|---------|
| Snow Tank Down | 4.04 m | 2.13 m | 2.26 m | 159 in. | 84 in. | 89 in.  |
| Snow Tank Up   | 5.03 m | 2.13 m | 3.73 m | 198 in. | 84 in. | 147 in. |

### Shaving Blade

|                         | L        | W       | H       | L      | W     | H       |
|-------------------------|----------|---------|---------|--------|-------|---------|
| 195.6 cm   77 in. Blade | 195.6 cm | 12.7 cm | 1.27 cm | 77 in. | 5 in. | 0.5 in. |

### Clearance

|                                   |  |          |          |
|-----------------------------------|--|----------|----------|
| Minimum Operator Height Clearance |  | 248.9 cm | 98 in.   |
| Snow Pit Clearance                |  | 125.7 cm | 49.5 in. |

### Conveyor System

|                           |         |        |
|---------------------------|---------|--------|
| Horizontal Auger Diameter | 25.4 cm | 10 in. |
| Vertical Auger Diameter   | 25.4 cm | 10 in. |

### Manueverability

|                               |        |        |
|-------------------------------|--------|--------|
| Wheelbase                     | 1.96 m | 77 in. |
| Wheel Track                   | 1.37 m | 54 in. |
| Turning Radius at Conditioner | 4.87 m | 16 ft. |

### Weight

|                                     |         |          |
|-------------------------------------|---------|----------|
| Empty with Lead Acid battery        | 4423 kg | 9750 lb  |
| With Water with Lead Acid battery   | 5148 kg | 11350 lb |
| Empty with Lithium-ion battery      | 3311 kg | 7300 lb  |
| With Water with Lithium-ion battery | 4037 kg | 8900 lb  |

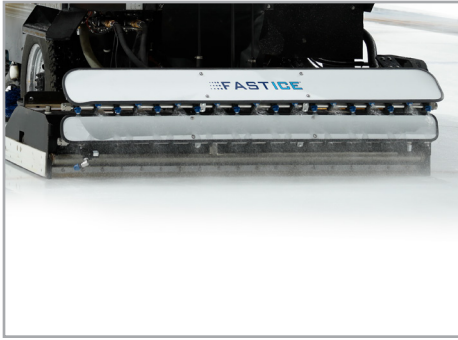

### FASTICE® Ice Making System

Create superior ice with a computer controlled pump for an even and accurate fine mist water application. \*optional equipment



### Level-Ice® Laser Leveling System

Automated precision blade control provides consistently level ice and significant savings of energy, water and time. \*optional equipment



### Zamboni Connect™ System

Monitor consumption and optimize performance with predictive insight and resource management. \*optional equipment

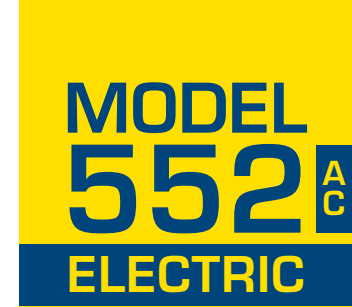

#### ✓ STANDARD FEATURES

- 2 Year Warranty
- 400 Micron Wash Water Deep Filter Bag
- Aluminum Alloy Wheels
- Battery: Lead Acid
- Battery Charger: Microprocessor Controlled
- Brushless AC Motors
- Chassis: Strong All Welded Steel Tubing
- Conditioner Safety Guards
- Dependable Sevcon® Gen4 Solid State Controls
- Digital Training and Reference Materials
- Familiar Automobile-Style Foot Controls
- Four-Wheel Drive
- Guide Wheel
- High Quality 9 Micron Filter
- High Speed Vertical Auger
- Hydraulic Oil Level Sight Gauge
- LED Headlights and Tail Lights
- On-Dash Diagnostics

- Parking Brake
- Power Steering
- Premium Polyester Felt Spreader Towel
- Replaceable Poly Conditioner Side Plates
- Rugged Dana Spicer® Axles
- Rust-Free Poly Ice Making Water Tank
- Snow Tank Safety Stand
- Spare Tire and Wheel
- Stainless Steel Hardware
- Steering Wheel Spinner Knob
- Touch Up Paint Kit
- Tungsten Carbide Studded Tires
- Variable Speed Electric Hydraulic Pump Motor
- Wide Spectrum of Premium Automotive Paint Colors

#### + OPTIONS

- Advanced Water System (AWS™)
- Automatic Snow Breaker
- Back Up Alarm
- Battery: Lithium-ion
- [Blade Change System](#)
- Cab Enclosure
- Conditioner: 96" Blade
- Conditioner: Galvanized
- Electric Water Level Gauge
- [FastICE® Ice Making System](#)
- IceCaps® Wheel Advertising System
- Heated Ergonomic Comfort Design Seat
  - Armrest
  - Seatbelt
- Integrated Auger Washout System
- [Level-Ice®](#)
- Low Guide Wheel
- Seat Belt
- Snow Melting Kit

- Snow Tank Dump Height Restriction
- Snow Tank Light
- Stainless Steel Water Distribution Pipe
- Tire Wash System
- Wash Water to Ice Making Water Transfer
- Wash Water System with Poly Tank
- Water Level Sight Gauge
- Zamboni Power Brush™ Board Brush System
- [Zamboni Connect™ System](#)