

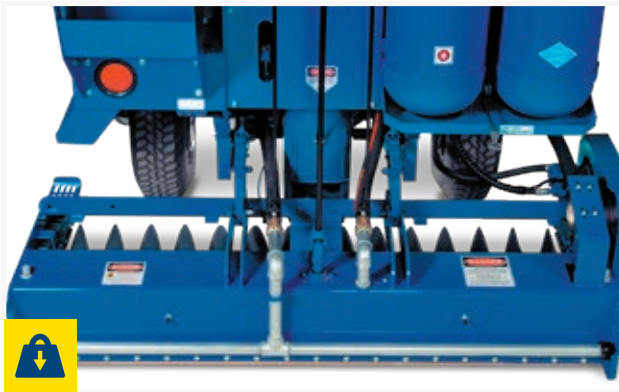

## POWER AND EFFICIENCY WITHOUT COMPROMISE

The powerful high-output compact engine introduces a new era of fuel efficiency, providing significant savings and a cleaner arena environment.

**MODEL  
526**



Reduced fuel consumption without compromise of performance



Ease of operation with familiar automobile style controls and gauges



Exceptional results from our unrivaled down pressure system



## POWER AND EFFICIENCY

The compact 2.4 L engine can be configured for gasoline, propane or CNG. On-board diagnostics with programmed oil change and maintenance intervals.



## TRANSMISSION

Continuously variable hydrostatic pump and motor are axial-piston type, providing superior on-ice power with maximum drawbar pull. Full hydrodynamic braking.



## DRIVETRAIN

Four-wheel drive. Rugged Dana Spicer® axles combine with an innovative hydrostatic transmission, providing the most reliable drivetrain in the industry.



## HYDRAULICS

Efficient double pump delivers full power and speed to the augers, even while the machine slows for corners. Easy access to high quality, low maintenance filters.



## CONSTRUCTION

Robust hand-welded steel tubing chassis. Premium primer/paint and rust-free poly ice-making water tank for corrosion resistance in the harsh environment it will call home.



## GLOBAL SERVICE AND SUPPORT

Zamboni Customer Service and a network of Zamboni Authorized Distributors provide exceptional and accessible service and support worldwide.

# ZAMBONI

[zamboni.com](http://zamboni.com)

# MODEL 526



This brochure has been prepared only as a general guide for the customer. Every effort has been made to assure that the information presented is correct. Some features described or shown may be optional at extra cost. Prices, colors, materials, specifications and models are subject to change. For current product information, please contact the Zamboni Company.

ZAMBONI and the configuration of the Zamboni® ice resurfacing machine are registered trademarks of Frank J. Zamboni & Co., Inc.  
© Zamboni 2022

# MODEL 526

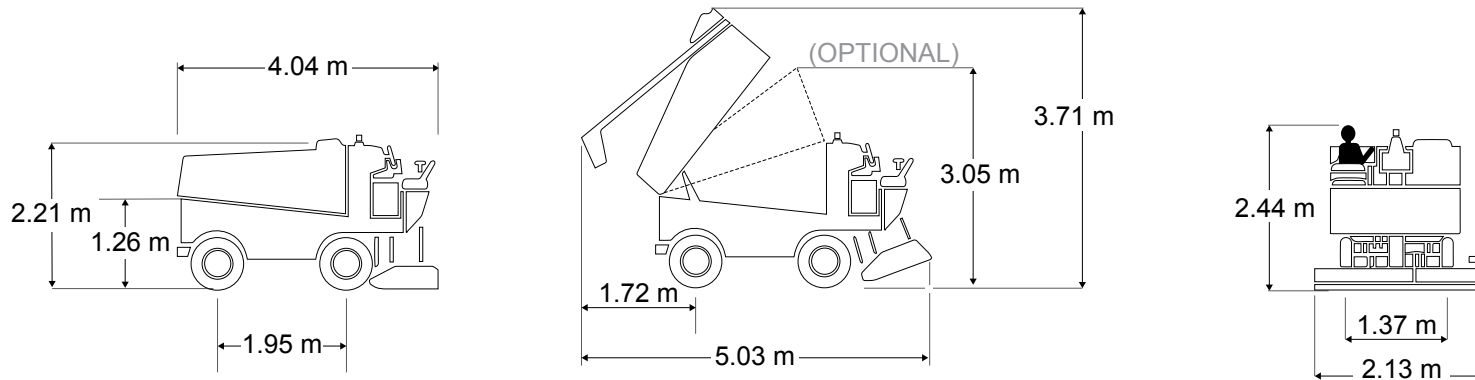

CAPACITIES		
<b>Snow Tank</b>		
Actual Volume	2.83 m <sup>3</sup>	100 cu. ft.
Compacted	3.54 m <sup>3</sup>	125 cu. ft.
Excess Water	416 L	110 gal.
<b>Water</b>		
Ice Making	727 L	192 gal.
Wash Water	273 L	72 gal.
Total	1000 L	264 gal.
<b>Hydraulic Oil</b>	95 L	25 gal.
POWERTRAIN		
Four-Wheel Drive		
Engine	Mitsubishi® 2.4 L / 59 HP at 2500 RPM Four Cylinder Liquid Cooled	
Transmission	Continuously variable hydrostatic pump and motor are axial-piston type.	
Hydraulics	Double pump powers the vertical and horizontal augers. Hydraulic down pressure for optimal resurfacing results.	
<b>Axles</b>		
Front	1950 kg	4300 lb
Rear	2903 kg	6400 lb
<b>Brakes</b>	Full Hydrodynamic Braking	

DIMENSIONS						
<b>Overall</b>	<b>L</b>	<b>W</b>	<b>H</b>	<b>L</b>	<b>W</b>	<b>H</b>
Snow Tank Down	4.04 m	2.13 m	2.21 m	159 in.	84 in.	87 in.
Snow Tank Up	5.03 m	2.13 m	3.71 m	198 in.	84 in.	146 in.
<b>Shaving Blade</b>	<b>L</b>	<b>W</b>	<b>H</b>	<b>L</b>	<b>W</b>	<b>H</b>
	195.6 cm	12.7 cm	1.27 cm	77 in.	5 in.	0.5 in.
<b>Clearance</b>						
Minimum Operator Height Clearance			243.8 cm			96 in.
Snow Pit Clearance			125.7 cm			49.5 in.
<b>Conveyor System</b>						
Horizontal Auger Diameter			25.4 cm			10 in.
Vertical Auger Diameter			25.4 cm			10 in.
<b>Manueverability</b>						
Wheelbase			1.96 m			77 in.
Wheel Track			1.37 m			54 in.
Turning Radius at Conditioner			4.86 m			16 ft.
<b>Weight</b>						
Empty			3143 kg			6930 lb
with Water			4240 kg			9350 lb

✓ Standard + Option



Some features described or shown may be optional at extra cost and prices, colors, materials, specifications and models are subject to change. Some options are required in combination with other options. ZAMBONI and the configuration of the Zamboni® ice resurfacing machine are registered trademarks of Frank J. Zamboni & Co., Inc. © Zamboni 2023 Rev 01/2023



#### Advanced Water System — AWS™

Regulates amount of water dispensed onto the ice relative to machine speed for efficient and even application. \*optional equipment



#### Zamboni Power Brush™

Wider brush path reaches higher on the dasher board kick plate for superior cleaning power. \*optional equipment



#### Integrated Auger Washout System

Simplifies the vertical and horizontal auger washout task, from a single point on the conditioner. \*optional equipment



### ✓ STANDARD FEATURES

2 Year Warranty  
 400 Micron Wash Water Deep Filter Bag  
 Aluminum Alloy Wheels  
 Catalytic Converter  
 Chassis: Strong All Welded Steel Tubing  
 Conditioner Safety Guards  
 Digital Training and Reference Materials  
 Engine: CAN Bus System  
 Engine: EPA and CARB Certified  
 Familiar Automobile-Style Foot Controls  
 Four-Wheel Drive  
 Fuel: Gasoline, Propane (CNG optional)  
 Full Hydrodynamic Braking  
 Guide Wheel  
 High Quality 16 and 22 Micron Filters  
 High Speed Vertical Auger  
 Hydraulic Oil Level Sight Gauge  
 LED Headlights and Tail lights  
 Load Sensing Engine Governor

Multi-Function Display  
 On-Dash Diagnostics  
 Parking Brake  
 Power Steering  
 Premium Polyester Felt Spreader Towel  
 Replaceable Poly Conditioner Side Plates  
 Rugged Dana Spicer® Axles  
 Snow Tank Safety Stand  
 Spare Tire and Wheel  
 Stainless Steel Hardware  
 Stainless Steel Water Distribution Pipe  
 Steering Wheel Spinner Knob  
 Touch-Up Paint Kit  
 Tungsten Carbide Studded Tires  
 Under Seat Storage  
 Wash Water  
 Wide Spectrum of Premium Automotive Paint Colors

### + OPTIONS

Advanced Water System (AWS™)  
 Automatic Snow Breaker  
 Back Up Alarm  
[Blade Change System](#)  
 Cab Enclosure  
 Conditioner: 96" Blade  
 Conditioner: Galvanized  
 Engine Diagnostic Computer Interface Tool  
[FastICE® Ice Making System](#)  
 Fire Extinguisher  
 Front Squeegee  
 Heated Ergonomic Comfort Design Seat
 

- Armrest
- Seatbelt

 Hydraulic Oil Cooler Kit  
 IceCaps® Wheel Advertising System  
 Integrated Auger Washout System  
 LED Headlights  
[Level-Ice™](#)

Rotating Beacon Light  
 Rust-Free Poly Ice Making Water Tank  
 Snow Melting Kit  
 Snow Tank Dump Height Restriction  
 Snow Tank Light  
 Snow Tank Non-Stick Liner  
 Tire Wash System  
 V-Plow  
 Water Level Sight Gauge  
 Wash Water to Ice Making Water Transfer  
[Zamboni Connect™ System](#)  
 Zamboni Power Board Brush™ System