

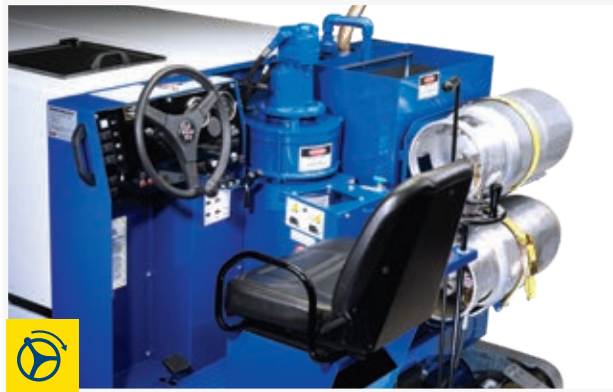

POWER WITH EXCEPTIONAL MANEUVERABILITY

The powerful high-output compact engine introduces a new era of fuel efficiency, providing significant savings and a cleaner arena environment.

**MODEL
446**



Reduced fuel consumption without compromise of performance



Ease of operation with familiar automobile style controls and gauges



Exceptional results from our unrivaled down pressure system



POWER AND EFFICIENCY

The compact 2.4 L engine can be configured for gasoline, propane or CNG. On-board diagnostics with programmed oil change and maintenance intervals.



TRANSMISSION

Continuously variable hydrostatic pump and motor are axial-piston type, providing superior on-ice power with maximum drawbar pull. Full hydrodynamic braking.



DRIVETRAIN

Four-wheel drive. Rugged Dana Spicer® axles combine with an innovative hydrostatic transmission, providing the most reliable drivetrain in the industry.



HYDRAULICS

Efficient double pump delivers full power and speed to the augers, even while the machine slows for corners. Easy access to high quality, low maintenance filters.



CONSTRUCTION

Robust hand-welded steel tubing chassis. Premium primer/paint and rust-free poly ice-making water tank for corrosion resistance in the harsh environment it will call home.



GLOBAL SERVICE AND SUPPORT

Zamboni Customer Service and a network of Zamboni Authorized Distributors provide exceptional and accessible service and support worldwide.



MODEL 446



This brochure has been prepared only as a general guide for the customer. Every effort has been made to assure that the information presented is correct. Some features described or shown may be optional at extra cost. Prices, colors, materials, specifications and models are subject to change. For current product information, please contact the Zamboni Company.

ZAMBONI®

zamboni.com

ZAMBONI and the configuration of the Zamboni® ice resurfacing machine are registered trademarks of Frank J. Zamboni & Co., Inc.
© Zamboni 2022

MODEL 446

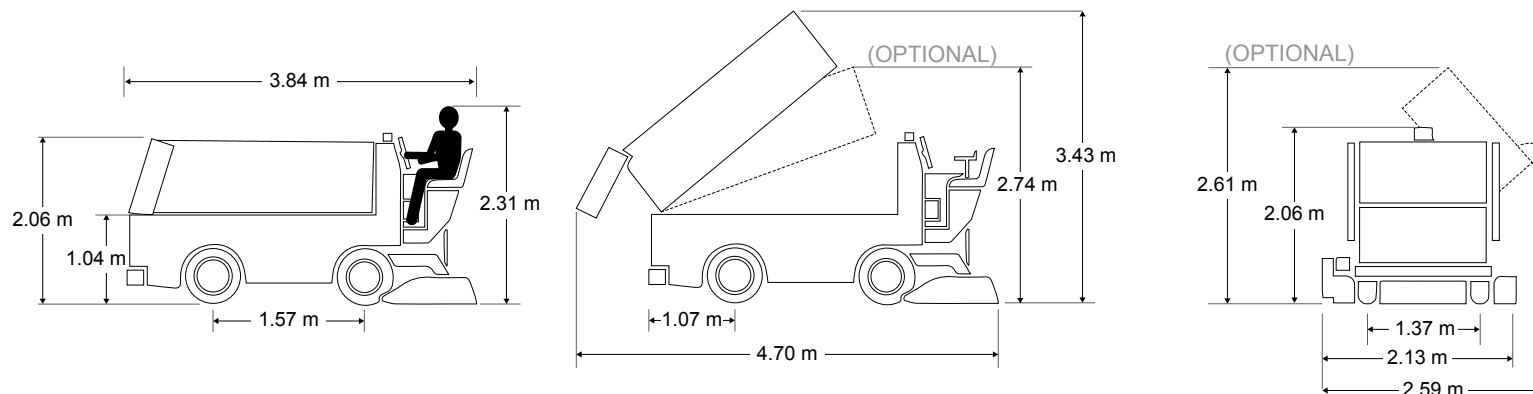

CAPACITIES

Snow Tank

Actual Volume	2.66 m ³	94 cu. ft.
Compacted	3.17 m ³	112 cu. ft.

Water

Ice Making	627 L	166 gal.
Wash Water	218 L	58 gal.
Total	845 L	224 gal.

Hydraulic Oil	72 L	19 gal.
----------------------	------	---------

POWERTRAIN

Four-Wheel Drive

Engine Mitsubishi® 2.4 L / 59 HP at 2500 RPM
Four Cylinder Liquid Cooled

Transmission Continuously variable hydrostatic pump and motor are axial-piston type.

Hydraulics Powerful single pump for the vertical and horizontal augers.
Hydraulic down pressure for optimal resurfacing results.

Axles

Front	1950 kg	4300 lb
Rear	2177 kg	4800 lb

Brakes Full Hydrodynamic Braking with Rear Drum Brakes

✓ Standard + Option

DIMENSIONS

Overall	L	W	H	L	W	H
Snow Tank Down	3.84 m	2.13 m	2.06 m	151 in.	84 in.	81 in.
Snow Tank Up	4.70 m	2.13 m	3.43 m	185 in.	84 in.	135 in.
Shaving Blade	L	W	H	L	W	H
	195.6 cm	12.7 cm	1.27 cm	77 in.	5 in.	0.5 in.

Clearance

Minimum Operator Height Clearance	2.31 m	91 in.
Snow Pit Clearance	104.1 cm	41 in.

Conveyor System

Horizontal Auger Diameter	25.4 cm	10 in.
Vertical Auger Diameter	25.4 cm	10 in.

Manueverability

Wheelbase	1.57 m	62 in.
Wheel Track	1.37 m	54 in.
Turning Radius at Conditioner	4.57 m	15 ft.

Weight

Empty	2660 kg	5860 lb
with Water	3502 kg	7720 lb

MODEL 446

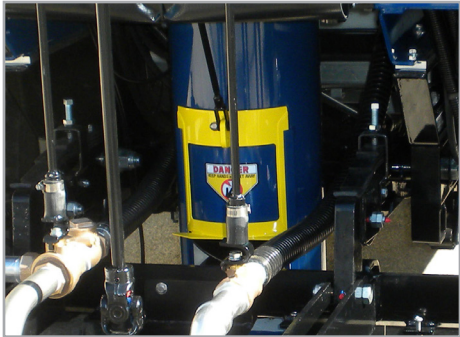

Automatic Snow Breaker

Eliminates the need for manual control of the snow breaker by the machine operator.

*optional equipment



Integrated Auger Washout System

Simplifies the vertical and horizontal auger washout task, from a single point on the conditioner.

*optional equipment



Ergonomic Seat

Designed with the operator in mind, our premium seat has optimal adjustability.

*optional equipment

✓ STANDARD FEATURES

2 Year Warranty
400 Micron Wash Water Deep Filter Bag
Aluminum Alloy Wheels
Catalytic Converter
Chassis: Strong All Welded Steel Tubing
Conditioner Safety Guards
Digital Training and Reference Materials
Engine: CAN Bus System
Engine: EPA and CARB Certified
Familiar Automobile-Style Foot Controls
Four-Wheel Drive
Fuel: Gasoline, Propane (CNG optional)
Full Hydrodynamic Braking
Guide Wheel
LED Headlights and Tail Light (for Off Ice Travel)
High Quality 10 and 25 Micron Filters
High Speed Vertical Auger
Hydraulic Oil Level Sight Gauge

Load Sensing Engine Governor
Multi-Function Display
On-Dash Diagnostics
Parking Brake
Power Steering
Premium Polyester Felt Spreader Towel
Replaceable Poly Conditioner Side Plates
Rugged Dana Spicer® Axles
Snow Tank Safety Stand
Spare Tire and Wheel
Stainless Steel Hardware
Steering Wheel Spinner Knob
Touch-Up Paint Kit
Tungsten Carbide Studed Tires
Under Seat Storage
Wide Spectrum of Premium Automotive Paint Colors

+ OPTIONS

Automatic Snow Breaker
Back Up Alarm
[Blade Change System](#)
Conditioner: Galvanized
Electric Water Level Gauge
Engine Diagnostic Computer Interface Tool
Fire Extinguisher
Heated Ergonomic Comfort Design Seat

- Armrest
- Seatbelt

Hydraulic Oil Cooler Kit
IceCaps® Wheel Advertising System
Integrated Auger Washout System
[Level-Ice™](#)
Low Fuel Light
Rotating Beacon Light
Side Snow Tank Dump
Snow Melting Kit
Snow Tank Dump Height Restriction

Snow Tank Light
Snow Tank Non-Stick Liner
Stainless Steel Water Distribution Pipe
Tire Wash System
Wash Water
Wash Water to Ice Making Water Transfer
Water Level Sight Gauge
[Zamboni Connect™ System](#)
Zamboni Power Board Brush™ System