





## INDUSTRY LEADING CAPACITIES AND SMART DESIGN

The exceptional water, blade and snow capacities are ideal for speed skating ovals, bandy rinks and large surfaces. Packed with features, this is the ultimate large capacity resurfacer.

**MODEL**  
**712**  
**ELECTRIC**



 Ergonomic blade angle adjustment wheel feature allows each operator to customize placement for ease of access.

 Internationally recognizable icons are grouped together on-dash to reference machine systems and functions.

 Cylindrical power board brush reaches higher for superior cleaning power and is a standard feature.



## BATTERY AND CHARGER

Industry-proven lead acid battery or optional lithium-ion battery technology. Microprocessor controlled chargers are customized to meet the needs of each facility. Battery watering system is standard.



## ELECTRONIC CONTROLS

Dependable AC controls. Two electric auger motors. Electrically operated water valves. Emergency stop feature. Electric wheel motors. On-dash display of battery capacity, water level and speed.



## HYDRAULICS

Electric hydraulic pump motor. Speed-related ice making water system controls water distribution. Safety valve for snow tank and conditioner hydraulics. Hydraulic all-wheel braking.



## STANDARD FEATURES

Automatic snow breaker; tire wash; water level gauges; back up alarm; non-stick snow tank liner; wash water to ice making water transfer; snow tank light; adjustable steering wheel; wash water flow monitor; extended hand rail and premium heated seat.



## CONSTRUCTION

Steel body panels and galvanized steel chassis/frame conditioner. Stainless steel high capacity water tanks. Rugged belt-driven augers reduce noise in operator area. Premium paint for corrosion resistance.

# ZAMBONI

[zamboni.com](http://zamboni.com)

ZAMBONI and the configuration of the Zamboni® ice resurfacing machine are registered trademarks of Frank J. Zamboni & Co., Inc.  
© Zamboni 2022

**MODEL  
712  
ELECTRIC**



This brochure has been prepared only as a general guide for the customer. Every effort has been made to assure that the information presented is correct. Some features described or shown may be optional at extra cost. Prices, colors, materials, specifications and models are subject to change. For current product information, please contact the Zamboni Company.

# MODEL 712 ELECTRIC

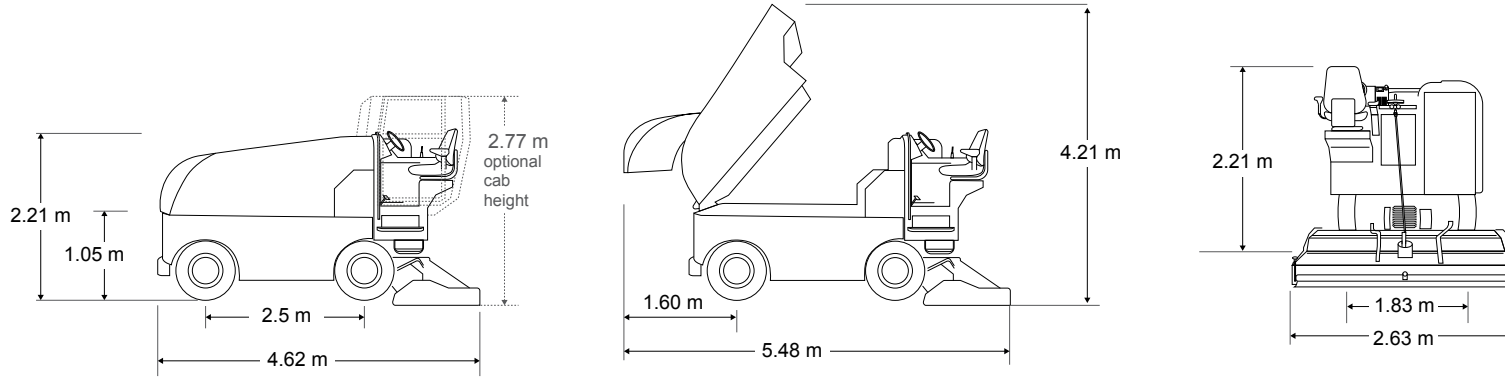

CAPACITIES		
<b>Snow Tank</b>		
Actual Volume	4.10 m <sup>3</sup>	145 cu. ft.
Compacted	5.13 m <sup>3</sup>	181 cu. ft.
<b>Water</b>		
Ice Making	1650 L	436 gal.
Wash Water	400 L	106 gal.
Total	2050 L	542 gal.
<b>Hydraulic Oil</b>	22 L	5.8 gal.
<b>POWERTRAIN</b> Four-Wheel Drive		
<b>Motors</b>		
Four Electric Wheel (traction) Motors	3.25 kW	4 HP
Electric Hydraulic Pump Motor	3 kW	4 HP
Two Electric Auger Motors	9 kW	12 HP
Total Energy Consumption of all Motors	34 kW	46 HP
<b>Battery</b>		
✔ Lead Acid or + Lithium-ion	*Accommodates a Variety of Battery Capacities	
<b>Axles</b>		
Front	7000 kg	15432 lb
Rear	7000 kg	15432 lb
<b>Brakes</b> Full Hydrodynamic Braking with Front and Rear Drum Brakes		
✔ Standard + Option		

DIMENSIONS						
<b>Overall</b>	<b>L</b>	<b>W</b>	<b>H</b>	<b>L</b>	<b>W</b>	<b>H</b>
Snow Tank Down	4.62 m	2.63 m	2.21 m	182 in.	104 in.	87 in.
Snow Tank Up	5.48 m	2.63 m	4.21 m	216 in.	104 in.	166 in.
<b>Shaving Blade</b>	<b>L</b>	<b>W</b>	<b>H</b>	<b>L</b>	<b>W</b>	<b>H</b>
	243.8 cm	12.7 cm	1.27 cm	96 in.	5 in.	0.5 in.
<b>Clearance</b>						
Minimum Operator Height Clearance			2.31 m			91 in.
Snow Pit Clearance			105 cm			41.3 in.
<b>Conveyor System</b>						
Horizontal Auger Diameter			25.4 cm			10 in.
Vertical Auger Diameter			25.4 cm			10 in.
Auger Length			243 cm			96 in.
<b>Manueverability</b>						
Wheelbase			2.50 m			98.4 in.
Wheel Track			1.80 m			70.9 in.
Turning Radius at Conditioner			3.95 m			13 ft.
<b>Weight</b>						
Empty with Lead Acid			5330 kg			11751 lb
With Water with Lead Acid			7380 kg			16270 lb
Empty with Lithium-ion			4218 kg			9301 lb
With Water with Lithium-ion			6268 kg			13820 lb



### Enclosed Cab

The enclosed operator cab provides protection from the elements and a safe, comfortable working space. \*optional equipment



### Zamboni Connect™ System

Monitor consumption and optimize performance with predictive insight and resource management. \*optional equipment

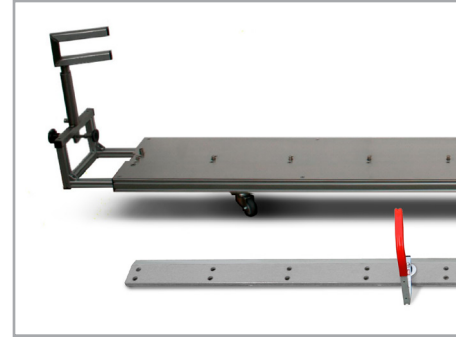

### Blade Change Assistant

Allows operators to complete a safe and easy blade installation or removal without touching the exposed blade. \*optional equipment



## ✓ STANDARD FEATURES

- 2 Year Warranty
- Adjustable Steering Wheel
- Auto Ice Button for an Automated Start and Stop to All Resurfacing Processes
- Automated Wash Water Pump Start
- Automatic Snow Breaker
- Backup Alarm
- Battery Watering System
- Battery: Lead Acid
- Blade Change Ease of Access From Above
- Brushless AC Motors and Controls
- Charger Adjusted to Customer Specs and Microprocessor Controlled
- Chassis: Strong All Welded Steel Tubing
- Closed Wash Water System
- Dual Auger Startup
- Dynamic Stability and Traction Control
- Electric Water Valve Operation
- Electric Wheel Motors
- Emergency Stop Button

- Ergonomic Blade Adjustment Wheel
- Four-Wheel Drive
- Galvanized Steel Frame Rear Swing Axle
- Guide Wheel
- Hydraulic All Wheel Braking
- Hydraulic Oil Vacuum Pump
- Fiberglass Hydraulic Snow Tank Lid
- Ice Making Water Level Gauge
- Integrated Snow Tank Safety Stand
- LED Headlights And Tail Light
- Automatic / Manual Ice Making Water Control
- Non-Stick Snow Tank Liner
- On-Dash Digital System Performance Display
- On-Dash View of Wash Water Return Flow
- Parking Brake
- Power Cylindrical Board Brush
- Power Steering
- Premium Adjustable / Heated Seat

- Premium Spreader Towel
- Preset Speed Options For Ice Maintenance, Ice Hockey And Bandy
- Replaceable Conditioner Runners
- Replaceable Poly Conditioner Side Plates
- Safety Valve on Hydraulic Cylinders for Snow Tank and Conditioner
- Snow Tank Light and View Panel
- Spare Tire and Wheel
- Speed-Related Ice Making Water System
- Stainless Steel Wash and Ice Making Water Tank
- Stainless Steel Water Distribution Pipe
- Steering Wheel Spinner Knob
- Tire Wash System and Studded Tires
- Transparent Auger Viewing Panels
- Variable Auger Speed Based on Water Flow
- Wash Water Level Gauge
- Wash Water to IMW Transfer System

## + OPTIONS

- Auger Washout System
- Automated Towel Bar Lift Raises Towel When Water Is Turned Off
- Battery: Lithium-ion
- Blade Change System
- Cab
- Front Camera
- Machine-Mounted Edger
- Seatbelt
- Spray Boom
- Touch Up Paint Kit
- Zamboni Connect™ System