

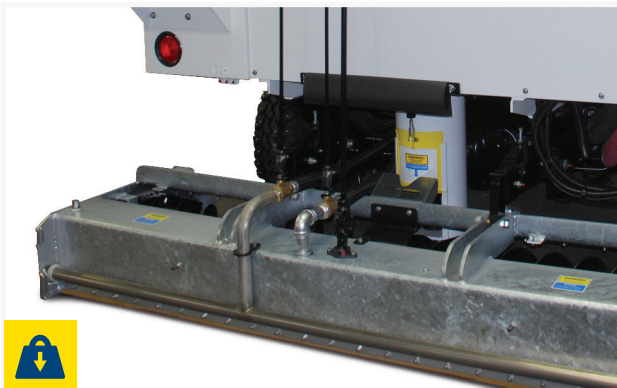

## INDUSTRY LEADING CAPACITIES ACROSS THE BOARD

Designed for large ice sheets, the Model 700 optimizes use of space for a dramatic increase in capacities. A wider blade and double the ice-making water makes swift work of big surfaces.

**MODEL  
700**

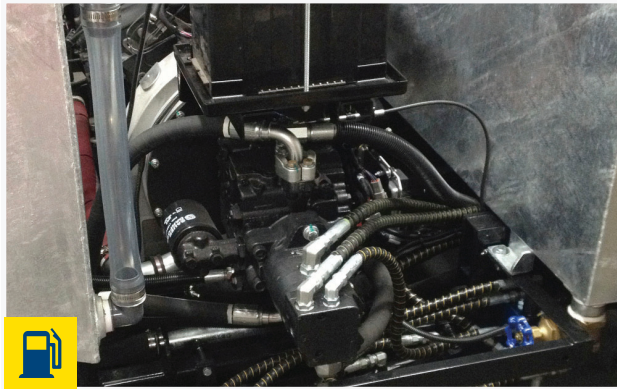

Powerful and efficient hydraulics deliver consistent performance at any speed.



Ease of operation with familiar automobile style controls and gauges



Exceptional results from our unrivaled down pressure system



## POWER AND EFFICIENCY

The six-cylinder 4.3 L engine powers through the additional demands of larger ice surfaces. Engine can be configured for gasoline or propane.



## TRANSMISSION

Continuously variable hydrostatic pump and motor are axial-piston type, providing superior on-ice power with maximum drawbar pull. Full hydro-dynamic braking.



## DRIVETRAIN

Four-wheel drive. Rugged Dana Spicer® axles combine with an innovative hydrostatic transmission, providing the most reliable drivetrain in the industry.



## HYDRAULICS

Efficient double pump delivers full power and speed to the augers, even while the machine slows for corners. Easy access to high quality, low maintenance filters.



## CONSTRUCTION

Robust hand-welded steel tubing chassis. Premium primer/paint and galvanized ice-making water tanks for corrosion resistance in the harsh environment it will call home.



## GLOBAL SERVICE AND SUPPORT

Zamboni Customer Service and a network of Zamboni Authorized Distributors provide exceptional and accessible service and support worldwide.

# ZAMBONI®

[zamboni.com](http://zamboni.com)

# MODEL 700



This brochure has been prepared only as a general guide for the customer. Every effort has been made to assure that the information presented is correct. Some features described or shown may be optional at extra cost. Prices, colors, materials, specifications and models are subject to change. For current product information, please contact the Zamboni Company.

ZAMBONI and the configuration of the Zamboni® ice resurfacing machine are registered trademarks of Frank J. Zamboni & Co., Inc.  
© Zamboni 2026

# MODEL 700

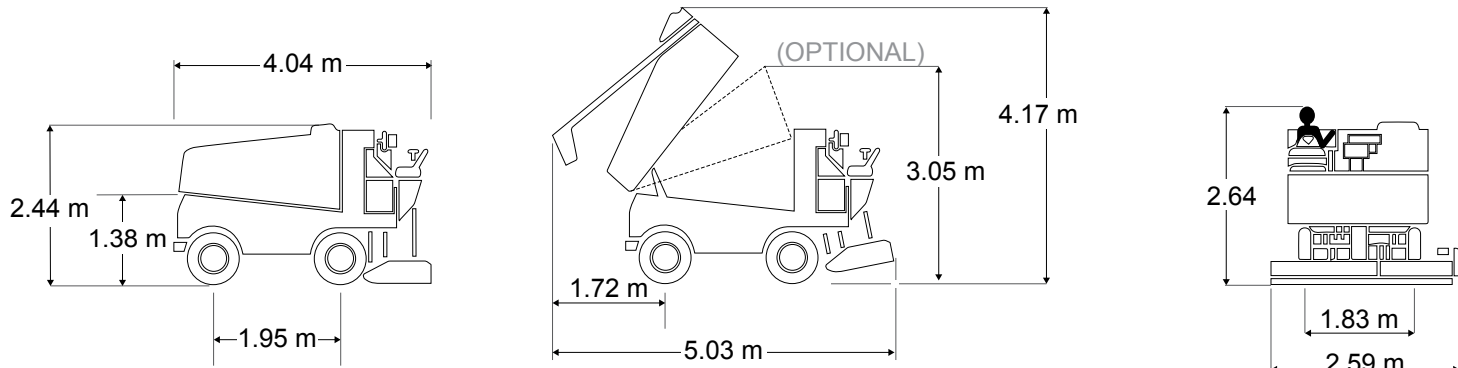

CAPACITIES		
<b>Snow Tank</b>		
Actual Volume	3.54 m <sup>3</sup>	125 cu. ft.
Compacted	4.53 m <sup>3</sup>	160 cu. ft.
Excess Water	662 L	175 gal.
<b>Water</b>		
Ice Making	1514 L	400 gal.
Wash Water	416 L	110 gal.
Total	1930 L	510 gal.
<b>Hydraulic Oil</b>	125 L	33 gal.
POWERTRAIN		
Four-Wheel Drive		
Engine	GM® 4.3 L Six Cylinder Engine 75 kW / 100 HP at 2800 RPM	
Transmission	Continuously variable hydrostatic pump and motor are axial-piston type.	
Hydraulics	Double pump powers the vertical and horizontal augers. Hydraulic down pressure for optimal resurfacing results.	
<b>Axles</b>	Rugged Dana Spicer® Model 70 Axles	
<b>Brakes</b>	Full Hydrodynamic Braking	

DIMENSIONS						
<b>Overall</b>	<b>L</b>	<b>W</b>	<b>H</b>	<b>L</b>	<b>W</b>	<b>H</b>
Snow Tank Down	4.04 m	2.59 m	2.44 m	159 in.	102 in.	96 in.
Snow Tank Up	5.03 m	2.59 m	4.17 m	198 in.	102 in.	164 in.
<b>Shaving Blade</b>	<b>L</b>	<b>W</b>	<b>H</b>	<b>L</b>	<b>W</b>	<b>H</b>
	243.8 cm	12.7 cm	1.27 cm	96 in.	5 in.	0.5 in.
<b>Clearance</b>						
Minimum Operator Height Clearance			264.2 cm		104 in.	
Snow Pit Clearance			1.38 m		54.5 in.	
<b>Conveyor System</b>						
Horizontal Auger Diameter			25.4 cm		10 in.	
Vertical Auger Diameter			25.4 cm		10 in.	
<b>Manueverability</b>						
Wheelbase			1.96 m		77 in.	
Wheel Track			1.83 m		72 in.	
Turning Radius at Conditioner			6.1 m		20 ft.	
<b>Weight</b>						
Empty			4273 kg		9420 lb	
with Water			6214 kg		13700 lb	

# MODEL 700



### Galvanized Conditioner

Durable galvanized steel provides a scratch-free finish with protection from rust.

\*optional equipment



### Zamboni Power Brush™

Wider brush path reaches higher on the dasher board kick plate for superior cleaning

power. \*optional equipment



### Automatic Snow Breaker

Eliminates the need for manual control of the snow breaker by the machine operator.

\*optional equipment

## STANDARD FEATURES

- 2 Year Warranty
- 400 Micron Wash Water Deep Filter Bag
- Chassis: Strong All Welded Steel Tubing
- Chrome Wheels
- Conditioner Safety Guards
- Digital Training and Reference Materials
- Engine: EPA and CARB Certified
- Familiar Automobile-Style Foot Controls
- Four-Wheel Drive
- Fuel Options: Gasoline, Propane
- Full Hydrodynamic Braking
- Galvanized Steel Ice Making Water Tank
- Guide Wheel
- High Quality 9 and 10 Micron Filters
- High Speed Vertical Auger
- Hydraulic Oil Level Sight Gauge
- LED Headlights and Tail lights
- Load Sensing Engine Governor
- Multi-Function Display
- On-Dash Diagnostics
- Parking Brake
- Power Steering
- Replaceable Poly Conditioner Side Plates
- Rugged Dana Spicer® Axles
- Snow Tank Safety Stand
- Spare Tire and Wheel
- Stainless Steel Hardware
- Steering Wheel Spinner Knob
- Touch-Up Paint Kit
- Tungsten Carbide Studded Tires
- Under Seat Storage
- Wide Spectrum of Premium Automotive Paint Colors

## OPTIONS

- Automatic Snow Breaker
- Back Up Alarm
- Cab Enclosure
- Conditioner: Galvanized
- Electric Water Level Gauge
- Heated Ergonomic Comfort Design Seat
  - Armrest
  - Seatbelt
- Hydraulic Oil Cooler Kit
- IceCaps® Wheel Advertising System
- Low Fuel Light
- Snow Melting Kit
- Snow Tank Dump Height Restriction
- Snow Tank Light
- Tire Wash System
- Wash Water to Ice Making Water Transfer
- Zamboni Power Brush™
- Board Brush System