



THE PERFECT BALANCE OF POWER AND EFFICIENCY

The clear choice for proven hydrostatic performance and significant fuel savings resulting in the industry's lowest emissions and a cleaner arena environment.

**MODEL
546**



Industry-leading fuel economy, reduced emissions and the lowest cost of operation for significant savings



Ease of operation with familiar automobile style controls and gauges



Exceptional results from our unrivaled down pressure system

**MODEL
546**



This brochure has been prepared only as a general guide for the customer. Every effort has been made to assure that the information presented is correct. Some features described or shown may be optional at extra cost. Prices, colors, materials, specifications and models are subject to change. For current product information, please contact the Zamboni Company.



POWER AND EFFICIENCY

The compact 1.6 L high output engine can be configured for gasoline or propane. On-board diagnostics with programmed oil change and maintenance intervals.



TRANSMISSION

Continuously variable hydrostatic pump and motor are axial-piston type, providing superior on-ice power with maximum drawbar pull. Full hydrodynamic braking.



DRIVETRAIN

Four-wheel drive. Rugged Dana Spicer® axles combine with an innovative hydrostatic transmission, providing the most reliable drivetrain in the industry.



HYDRAULICS

Efficient double pump delivers full power and speed to the augers, even while the machine slows for corners. Easy to access high quality, low maintenance filters.



CONSTRUCTION

Robust hand-welded steel tubing chassis. Premium primer/paint and rust-free poly water tanks for corrosion resistance in the harsh environment it will call home.



GLOBAL SERVICE AND SUPPORT

Zamboni Customer Service and a network of Zamboni Authorized Distributors provide exceptional and accessible service and support worldwide.

ZAMBONI

zamboni.com

ZAMBONI and the configuration of the Zamboni® ice resurfacing machine are registered trademarks of Frank J. Zamboni & Co., Inc.
© Zamboni 2022

MODEL 546

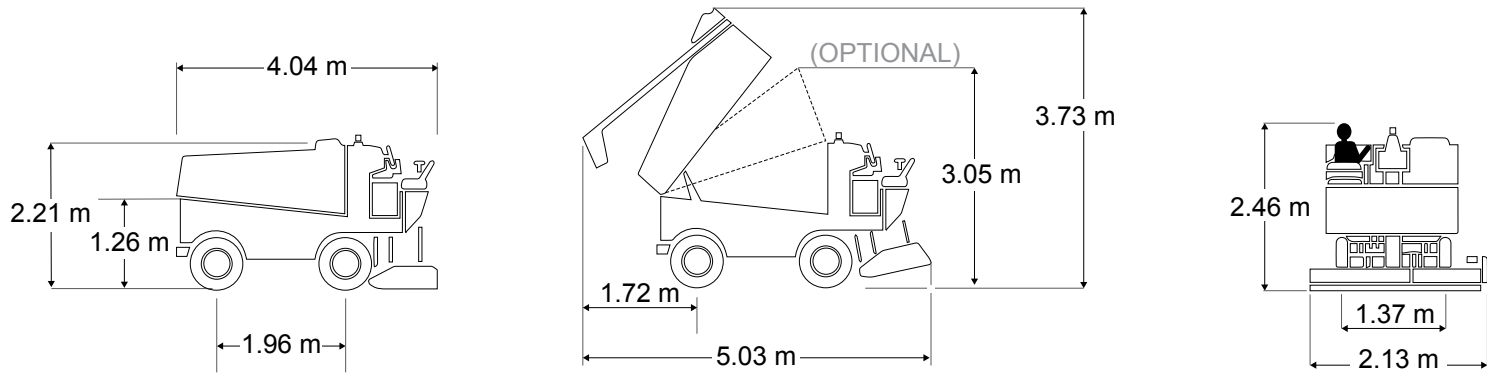

CAPACITIES		
Snow Tank		
Actual Volume	2.83 m ³	100 cu. ft.
Compacted	3.54 m ³	125 cu. ft.
Water		
Ice Making	738 L	195 gal.
Wash Water	310 L	82 gal.
Total	1048 L	277 gal.
Hydraulic Oil	95 L	25 gal.
POWERTRAIN		
Four-Wheel Drive		
Engine	Kubota® 1.6 L / 50 HP at 3000 RPM Four Cylinder Liquid Cooled	
Transmission	Continuously variable hydrostatic pump and motor are axial-piston type.	
Hydraulics	Double pump powers the vertical and horizontal augers. Hydraulic down pressure for optimal resurfacing results.	
Axles		
Front	1950 kg	4300 lb
Rear	2903 kg	6400 lb
Brakes	Full Hydrodynamic Braking	

✓ Standard + Option

DIMENSIONS						
Overall	L	W	H	L	W	H
Snow Tank Down	4.04 m	2.13 m	2.21 m	159 in.	84 in.	87 in.
Snow Tank Up	5.03 m	2.13 m	3.73 m	198 in.	84 in.	147 in.
Shaving Blade	L	W	H	L	W	H
	195.6 cm	12.7 cm	1.27 cm	77 in.	5 in.	0.5 in.
Clearance						
Minimum Operator Height Clearance			246.4 cm	97 in.		
Snow Pit Clearance			125.7 cm	49.5 in.		
Conveyor System						
Horizontal Auger Diameter			25.4 cm	10 in.		
Vertical Auger Diameter			25.4 cm	10 in.		
Manueverability						
Wheelbase			1.96 m	77 in.		
Wheel Track			1.37 m	54 in.		
Turning Radius at Conditioner			4.87 m	16 ft.		
Weight						
Empty			2912 kg	6420 lb		
with Water			3910 kg	8620 lb		



Advanced Water System — AWS™

Regulates amount of water dispensed onto the ice relative to machine speed for efficient and even application. *optional equipment



Zamboni Power Brush™

Wider brush path reaches higher on the dasher board kick plate for superior cleaning power. *optional equipment



Integrated Auger Washout System

Simplifies the vertical and horizontal auger washout task, from a single point on the conditioner. *optional equipment

**MODEL
546**

✓ STANDARD FEATURES

2 Year Warranty
 400 Micron Wash Water Deep Filter Bag
 Aluminum Alloy Wheels
 Catalytic Converter
 Chassis: Strong All Welded Steel Tubing
 Conditioner Safety Guards
 Digital Training and Reference Materials
 Engine: EPA and CARB Certified
 Familiar Automobile-Style Foot Controls
 Four-Wheel Drive
 Fuel Options: Gasoline, Propane
 Full Hydrodynamic Braking
 Guide Wheel
 High Quality 10 and 20 Micron Filters
 High Speed Vertical Auger
 Hydraulic Oil Level Sight Gauge
 LED Headlights and Tail lights
 Load Sensing Engine Governor
 Multi-Function Display

On-Dash Diagnostics
 Parking Brake
 Power Steering
 Premium Polyester Felt Spreader Towel
 Replaceable Poly Conditioner Side Plate
 Rugged Dana Spicer® Axles
 Rust-Free Poly Ice Making Water Tank
 Snow Tank Safety Stand
 Spare Tire and Wheel
 Stainless Steel Hardware
 Steering Wheel Spinner Knob
 Touch-Up Paint Kit
 Tungsten Carbide Studded Tires
 Under Seat Storage
 Wide Spectrum of Premium Automotive Paint Colors

+ OPTIONS

Advanced Water System (AWS™)
 Automatic Snow Breaker
 Back Up Alarm
[Blade Change System](#)
 Cab Enclosure
 Conditioner: Galvanized
 Electric Water Level Gauge
 Engine Diagnostic Computer Interface Tool
[FastICE® Ice Making System](#)
 Front Squeegee
 Heated Ergonomic Comfort Design Seat

- Armrest
- Seatbelt

 Hydraulic Oil Cooler Kit
 IceCaps® Wheel Advertising System
 Integrated Auger Washout System
[Level-Ice™](#)
 Low Fuel Light
 Low Guide Wheel

Snow Melting Kit
 Snow Tank Dump Height Restriction
 Snow Tank Light
 Stainless Steel Water Distribution Pipe
 Tire Wash System
 V-Plow
 Wash Water to Ice Making Water Transfer
 Wash Water System with Poly Tank
 Water Level Sight Gauge
 Zamboni Power Brush™ Board Brush System
[Zamboni Connect™ System](#)