



INDUSTRIAL STRENGTH ELECTRIC POWER

Introducing the high energy density of lithium-ion batteries to a proven and rugged workhorse for unbeatable electric-powered performance.

MODEL
450
LITHIUM-ION



Optional heavy duty battery package supports additional resurfacings



Ease of operation unique to the 400 Series includes directional foot pedal controls



Exceptional results from our unrivaled down pressure system



BATTERY AND CHARGER

High density lithium-ion batteries quickly charge between resurfacings while maintaining power.



ELECTRONIC CONTROLS

Dependable Sevcon® Gen4 AC controls. On-dash diagnostics provide real-time management of machine functions and status updates.



DRIVETRAIN

Four-wheel drive. Rugged Dana Spicer® axles combine with a 64 hp PMAC pump motor, providing the most reliable drivetrain in the industry.



TRANSMISSION

Continuously variable hydrostatic pump and motor are axial-piston type, providing superior on-ice power with maximum drawbar pull. Full hydrodynamic braking.



CONSTRUCTION

Robust hand-welded steel tubing chassis. Premium primer/paint and rust-free poly ice making water tank for corrosion resistance in the harsh environment it will call home.



GLOBAL SERVICE AND SUPPORT

Zamboni Customer Service and a network of Zamboni Authorized Distributors provide exceptional and accessible service and support worldwide.

ZAMBONI

zamboni.com

**MODEL
450
LITHIUM-ION**



This brochure has been prepared only as a general guide for the customer. Every effort has been made to assure that the information presented is correct. Some features described or shown may be optional at extra cost. Prices, colors, materials, specifications and models are subject to change. For current product information, please contact the Zamboni Company.

ZAMBONI and the configuration of the Zamboni® ice resurfacing machine are registered trademarks of Frank J. Zamboni & Co., Inc.
© Zamboni 2024

MODEL 450 ELECTRIC

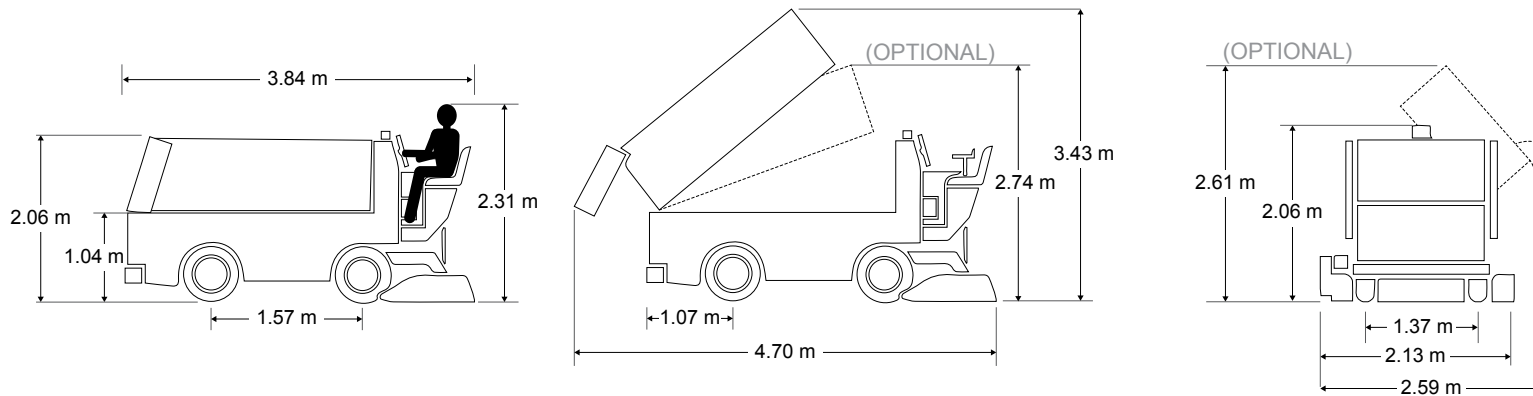

CAPACITIES

Snow Tank

Actual Volume	2.66 m ³	94 cu. ft.
Compacted	3.17 m ³	112 cu. ft.

Water

Ice Making	627 L	166 gal.
Wash Water	218 L	58 gal.
Total	845 L	224 gal.

Hydraulic Oil	72 L	19 gal.
----------------------	------	---------

POWERTRAIN

Four-Wheel Drive

Battery Lithium-ion
*Accommodates a Variety of Battery Capacities

Transmission Continuously variable hydrostatic pump and motor are axial-piston type.

Hydraulics Powerful single pump for the vertical and horizontal augers. Hydraulic down pressure for optimal resurfacing results.

Axles

Front	1950 kg	4300 lb
Rear	2177 kg	4800 lb

Brakes Full Hydrodynamic Braking with Rear Drum Brakes

Standard

DIMENSIONS

Overall	L	W	H	L	W	H
Snow Tank Down	3.84 m	2.13 m	2.06 m	151 in.	84 in.	81 in.
Snow Tank Up	4.70 m	2.13 m	3.43 m	185 in.	84 in.	135 in.
Shaving Blade	L	W	H	L	W	H
	195.6 cm	12.7 cm	1.27 cm	77 in.	5 in.	0.5 in.

Clearance

Minimum Operator Height Clearance	2.31 m	91 in.
Snow Pit Clearance	104.1 cm	41 in.

Conveyor System

Horizontal Auger Diameter	25.4 cm	10 in.
Vertical Auger Diameter	25.4 cm	10 in.

Manueverability

Wheelbase	1.57 m	62 in.
Wheel Track	1.37 m	54 in.
Turning Radius at Conditioner	4.57 m	15 ft.

Weight

Empty	2660 kg	5860 lb
with Water	3502 kg	7720 lb

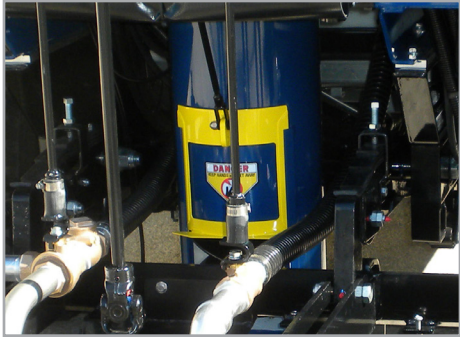

Automatic Snow Breaker

Eliminates the need for manual control of the snow breaker by the machine operator.

*optional equipment



Integrated Auger Washout System

Simplifies the vertical and horizontal auger washout task, from a single point on the conditioner.

*optional equipment



Ergonomic Seat

Designed with the operator in mind, our premium seat has optimal adjustability.

*optional equipment



✓ STANDARD FEATURES

2 Year Warranty
 400 Micron Wash Water Deep Filter Bag
 Aluminum Alloy Wheels
 Chassis: Strong All Welded Steel Tubing
 Conditioner Safety Guards
 Digital Training and Reference Materials
 Familiar Automobile-Style Foot Controls
 Four-Wheel Drive
 Full Hydrodynamic Braking
 Guide Wheel
 High Quality 10 and 25 Micron Filters
 High Speed Vertical Auger
 Hydraulic Oil Level Sight Gauge
 LED Headlights and Tail lights
 Load Sensing Motor Governor
 Motor: High Efficiency Permanent Magnet AC
 Motor Control: Sevcon Motor Control
 On-Dash Diagnostics
 Parking Brake

Power Steering
 Premium Polyester Felt Spreader Towel
 Replaceable Poly Conditioner Side Plates
 Rugged Dana Spicer® Axles
 Snow Tank Safety Stand
 Spare Tire and Wheel
 Steering Wheel Spinner Knob
 Touch-Up Paint Kit
 Tungsten Carbide Studded Tires
 Under Seat Storage
 Wide Spectrum of Premium Automotive Paint Colors

+ OPTIONS

Automatic Snow Breaker
 Back Up Alarm
 Battery and Motor Diagnostic Computer Interface Tool
[Blade Change System](#)
 Conditioner: Galvanized
 Electric Water Level Gauge
 Fire Extinguisher
 Heated Ergonomic Comfort Design Seat

- Armrest
- Seatbelt

 IceCaps® Wheel Advertising System
 Integrated Auger Washout System
[Level-Ice™](#)
 Rotating Beacon Light
 Side Snow Tank Dump
 Snow Melting Kit
 Snow Tank Dump Height Restriction
 Snow Tank Light
 Snow Tank Non-Stick Liner

Stainless Steel Water Distribution Pipe
 Tire Wash System
 Wash Water to Ice Making Water Transfer
 Water Level Sight Gauge
[Zamboni Connect™ System](#)
 Zamboni Power Board Brush™ System